CS688/WST665: Web-Scale Image Retrieval
Bag-of-Words (BoW) Models

Sung-Eui Yoon
(윤성익)

Course URL:
<http://sglab.kaist.ac.kr/~sungeui/IR>

KAIST



What we will learn today?

- Bag of Words models
 - Basic representation
 - Different learning and recognition algorithms

Object



Bag of 'words'



Fei-Fei Li

Analogy to documents

Of all the sensory impressions proceeding to the brain, the visual experiences are the dominant ones. Our perception of the world around us is based essentially on the messages that reach our eyes. For a long time, the retinal image was considered as a simple picture. As a result, the visual centers in the brain were thought of as a movie screen. However, the discovery of the retinal image by Hubel and Wiesel demonstrated that the message about the image falling on the retina undergoes a complex analysis in a system of nerve cells. In this system each cell has its specific function and is responsible for a specific detail in the pattern of the retinal image.

**sensory, brain,
visual, perception,
retinal, cerebral cortex,
eye, cell, optical
nerve, image
Hubel, Wiesel**

China is forecasting a trade surplus of \$90bn (£51bn) to \$100bn this year, a threefold increase on 2004's \$32bn. The Commerce Ministry said the surplus would be created by a predicted 30% increase in exports to \$750bn, compared with \$580bn in 2004. The surplus will annoy the US because it will reduce the US's trade deficit. China's government has deliberately kept the yuan's value low to encourage exports. The government also needs to keep the yuan's value low to meet the demand for yuan in the US market. China's government has permitted it to trade within a narrow range but the US wants the yuan to be allowed to trade freely. However, Beijing has made it clear that it will take its time and tread carefully before allowing the yuan to rise further in value.

**China, trade,
surplus, commerce,
exports, imports, US,
yuan, bank, domestic,
foreign, increase,
trade, value**

definition of “BoW”

– Independent features

face

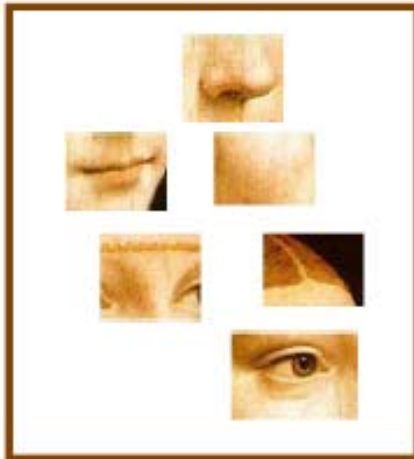

bike



violin



definition of “BoW”

- Independent features
- histogram representation

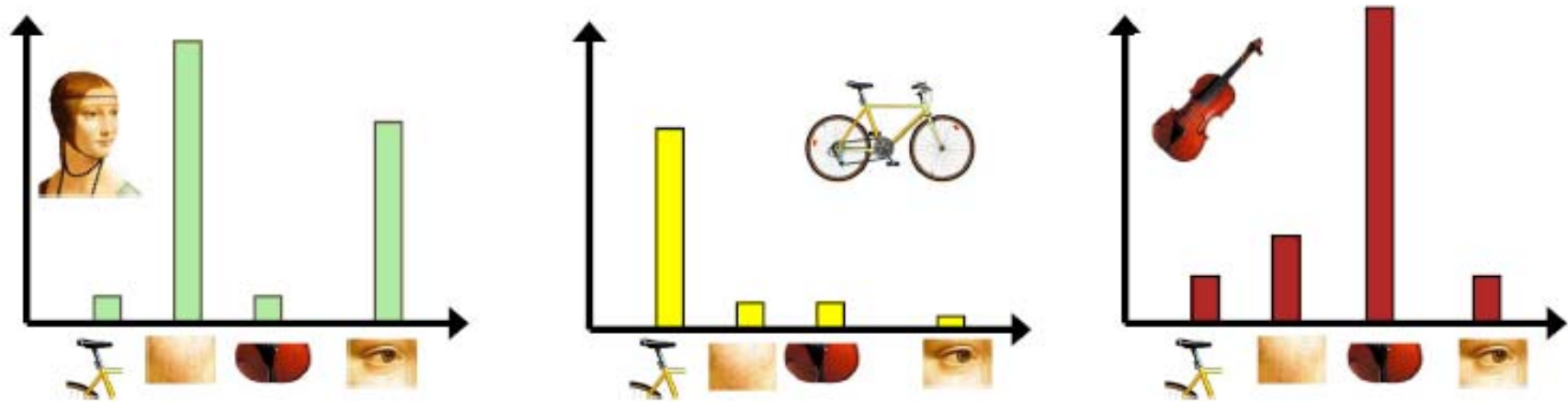

codewords dictionary

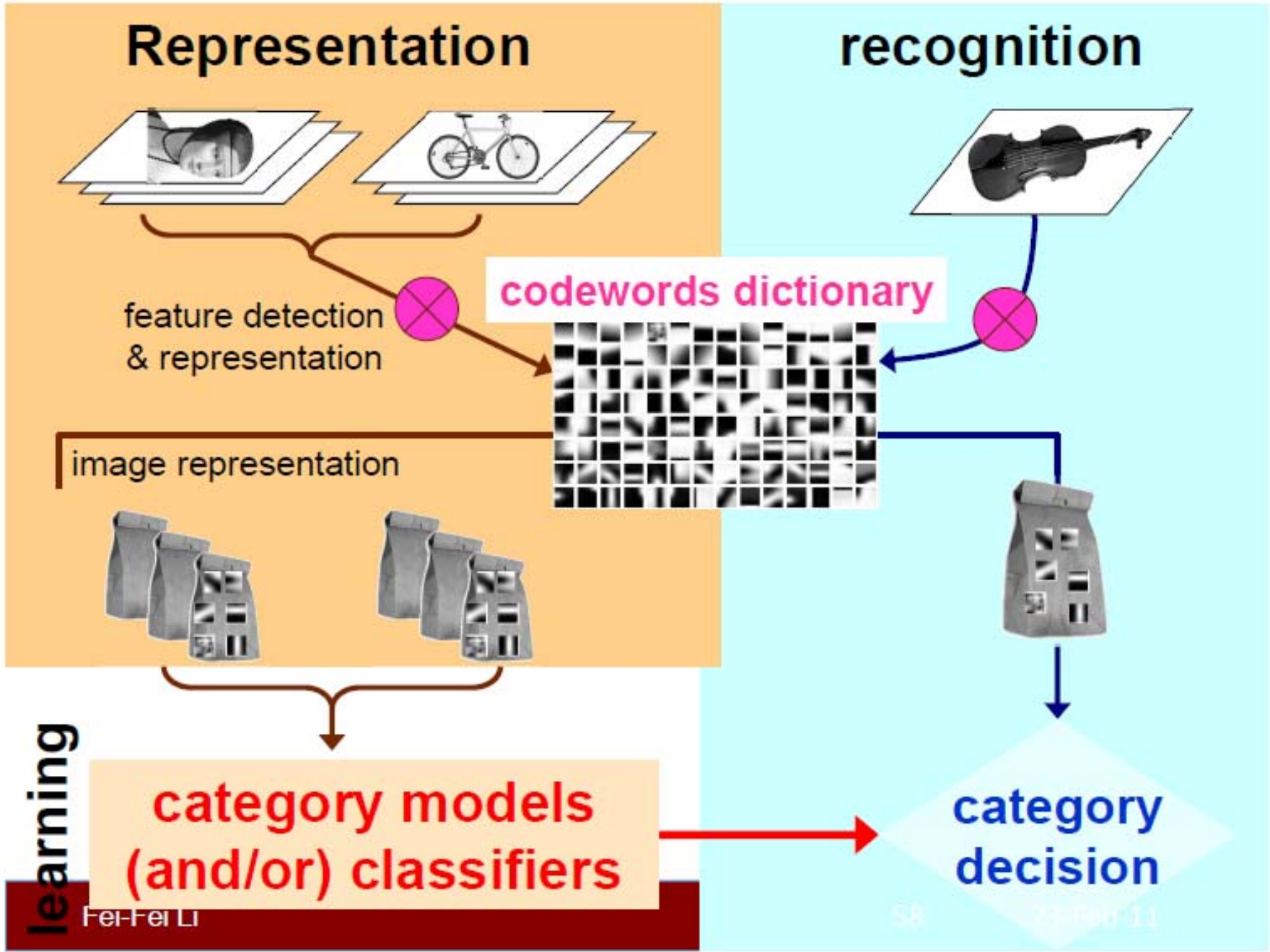

1. Feature detection and representation

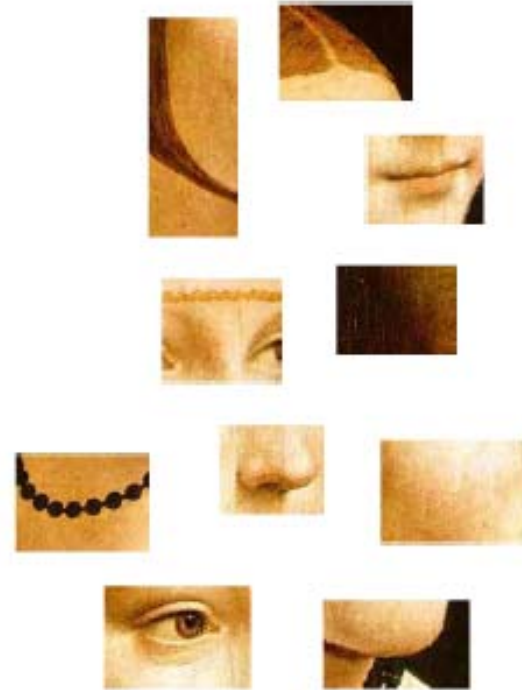

1.Feature detection and representation

- Regular grid
 - Vogel & Schiele, 2003
 - Fei-Fei & Perona, 2005
- Interest point detector
 - Csurka, Bray, Dance & Fan, 2004
 - Fei-Fei & Perona, 2005
 - Sivic, Russell, Efros, Freeman & Zisserman, 2005
- Other methods
 - Random sampling (Vidal-Naquet & Ullman, 2002)
 - Segmentation based patches (Barnard, Duygulu, Forsyth, de Freitas, Blei, Jordan, 2003)

1. Feature detection and representation



Compute
SIFT
descriptor
[Lowe'99]

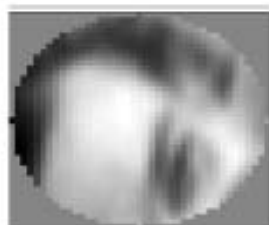

Normalize
patch

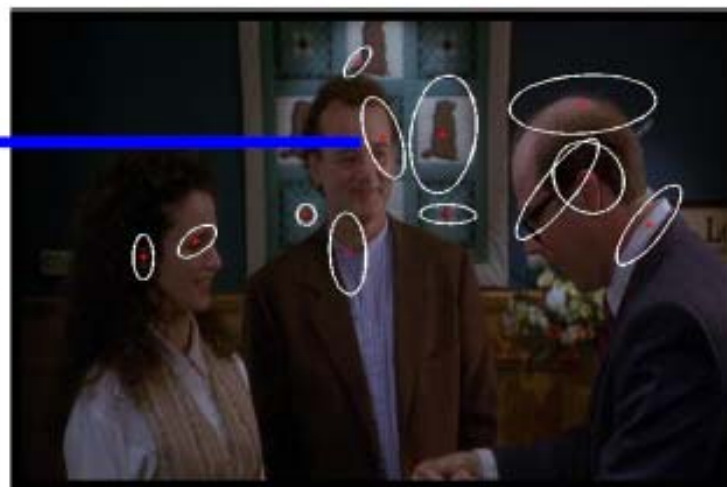

Detect patches

[Mikojaczyk and Schmid '02]

[Mata, Chum, Urban & Pajdla, '02]

[Sivic & Zisserman, '03]

Slide credit: Josef Sivic

1. Feature detection and representation

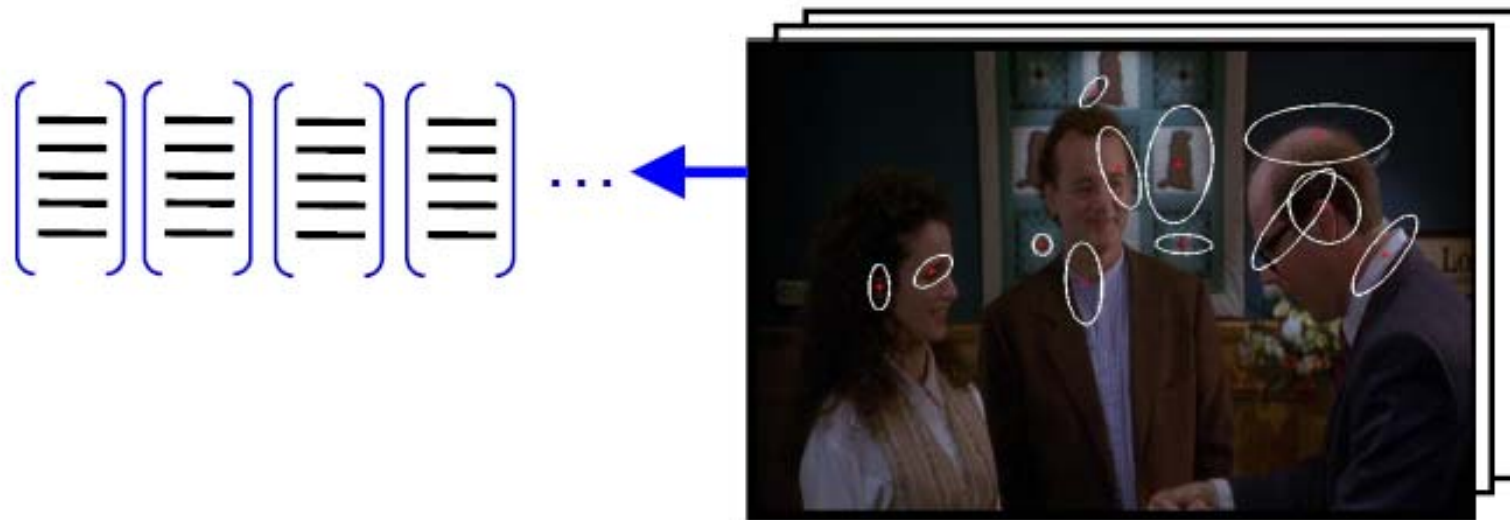

2. Codewords dictionary formation

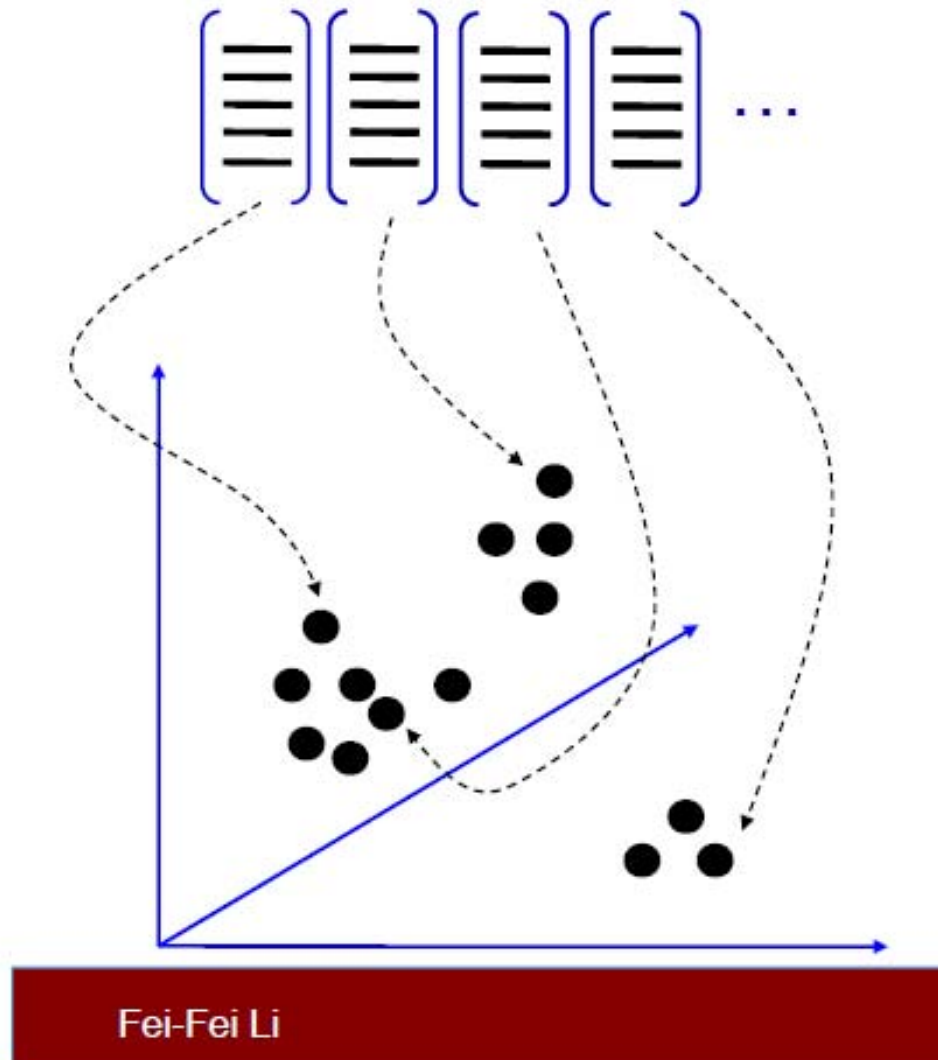

2. Codewords dictionary formation

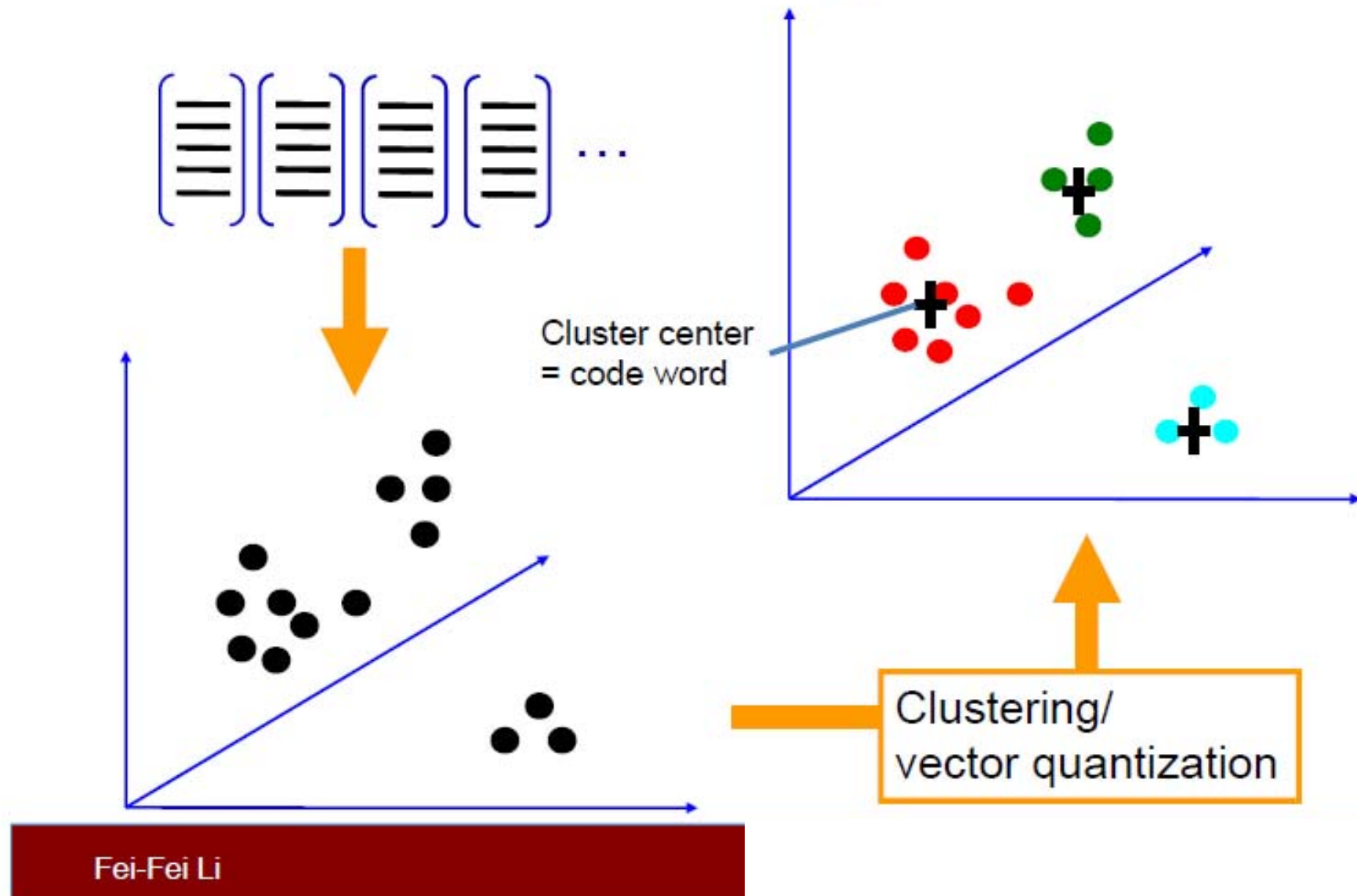

K-Means Clustering

- Minimizing the within-cluster sum of squares (WCSS)

$$\operatorname{argmin}_{\mathbf{S}} \sum_{i=1}^k \sum_{\mathbf{x}_j \in S_i} \|\mathbf{x}_j - \boldsymbol{\mu}_i\|^2$$

Demonstration of the standard algorithm

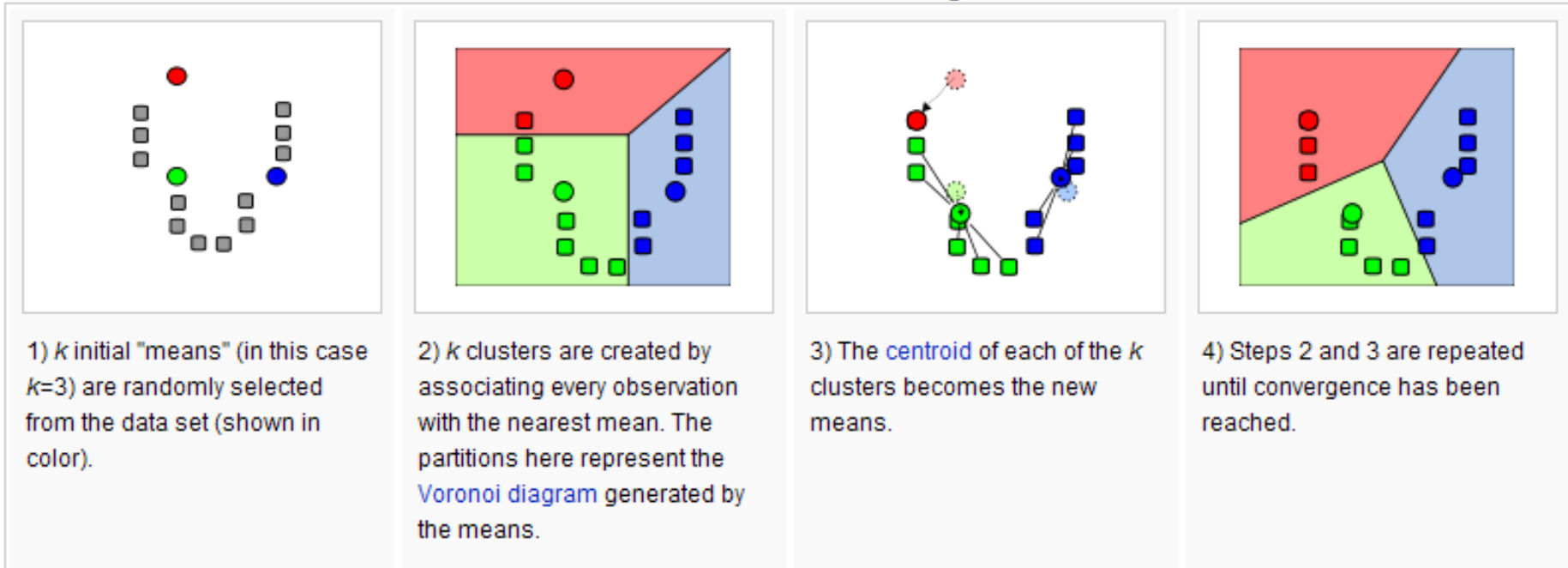

2. Codewords dictionary formation

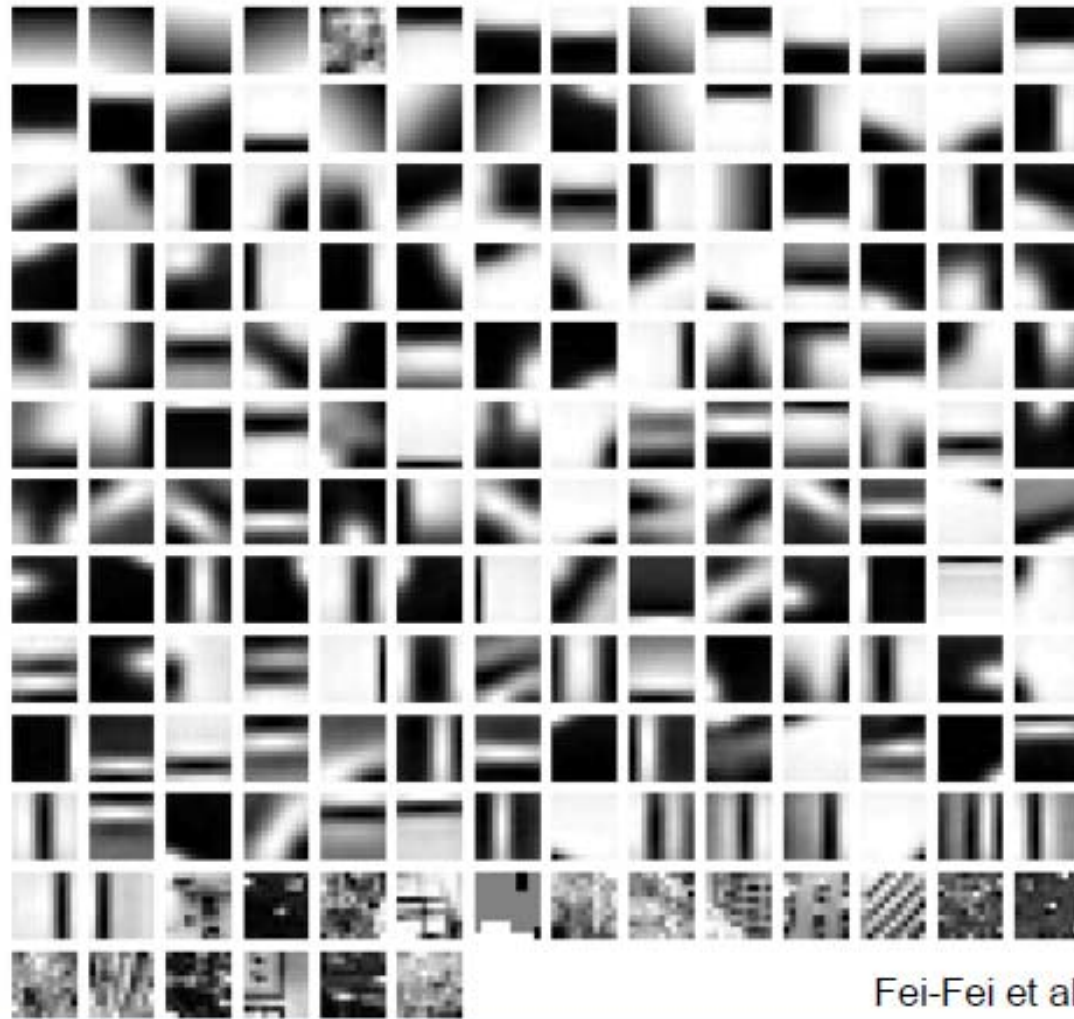

Fei-Fei et al. 2005

Image patch examples of codewords

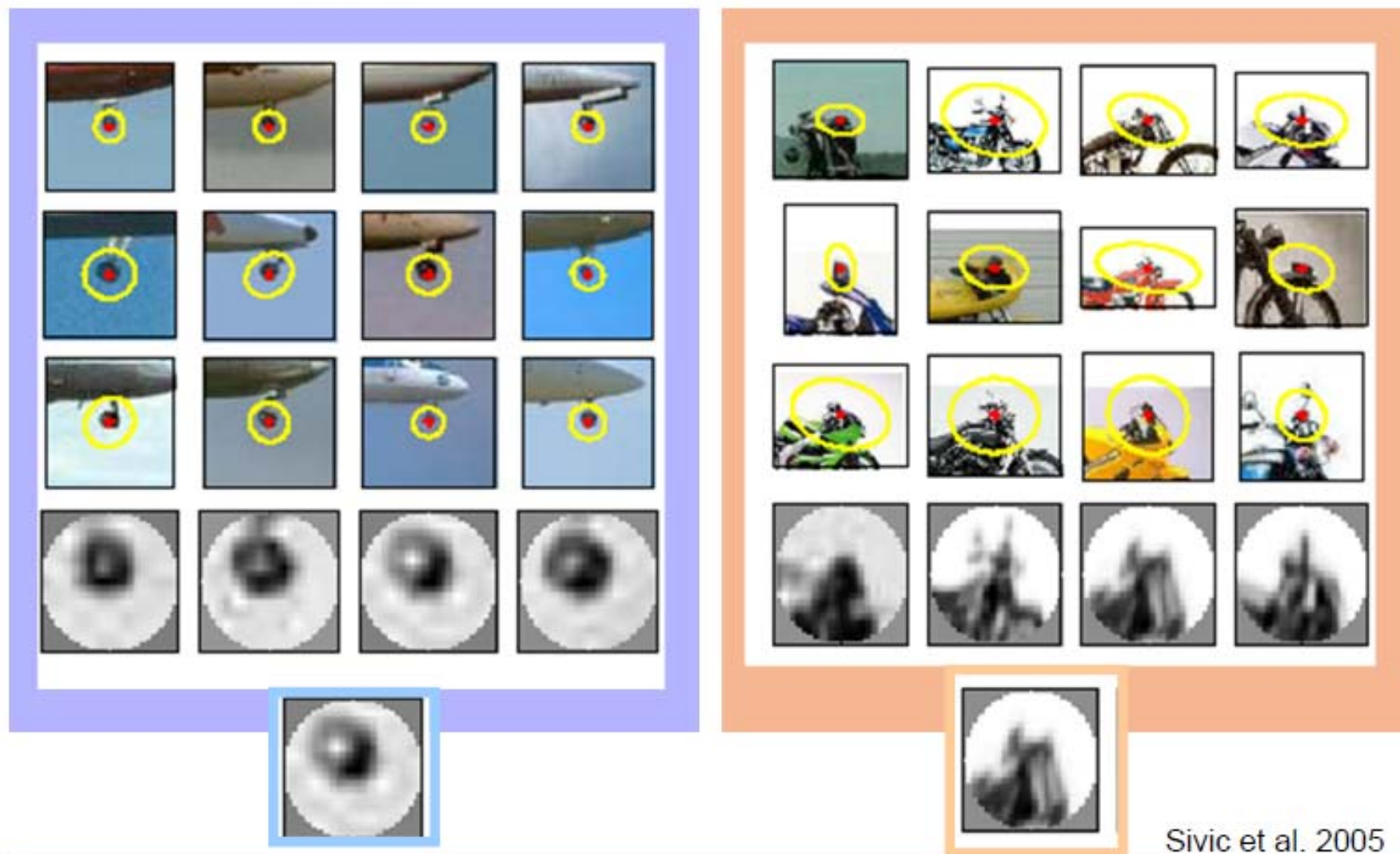

Sivic et al. 2005

Visual vocabularies: Issues

- How to choose vocabulary size?
 - Too small: visual words not representative of all patches
 - Too large: quantization artifacts, overfitting
- Computational efficiency
 - Vocabulary trees (Nister & Stewenius, 2006)

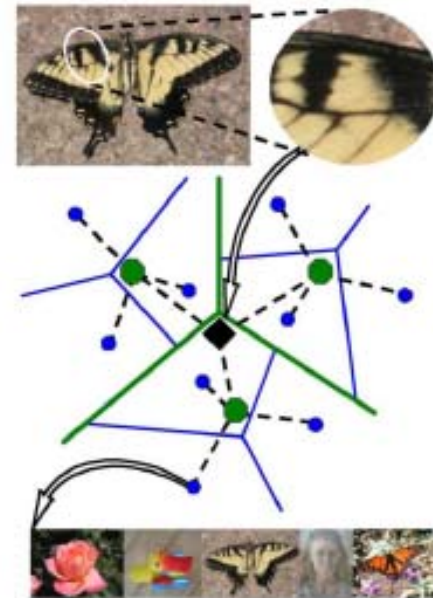

3. Bag of word representation

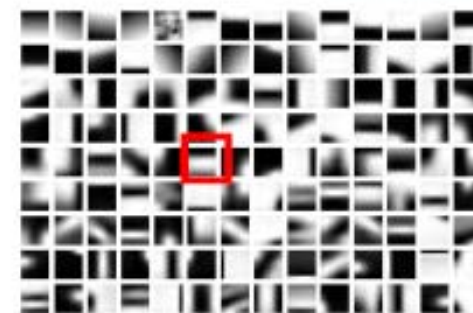
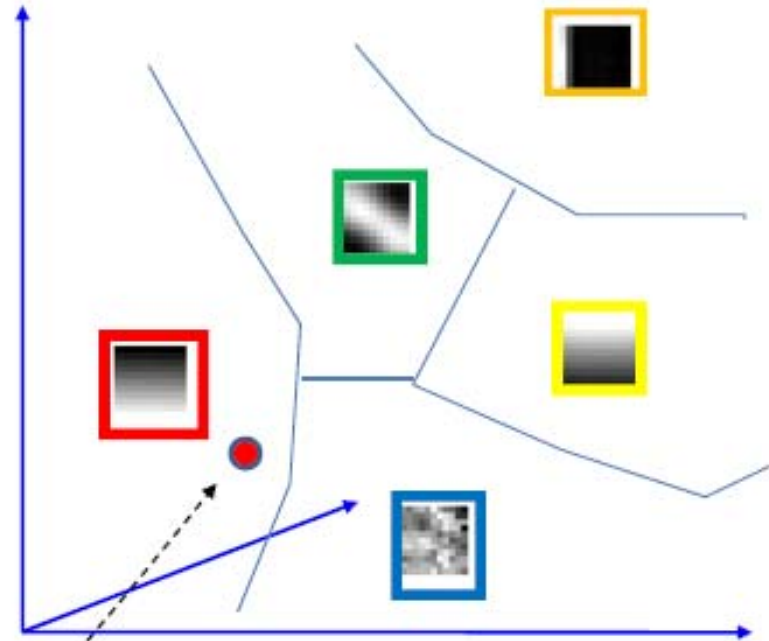
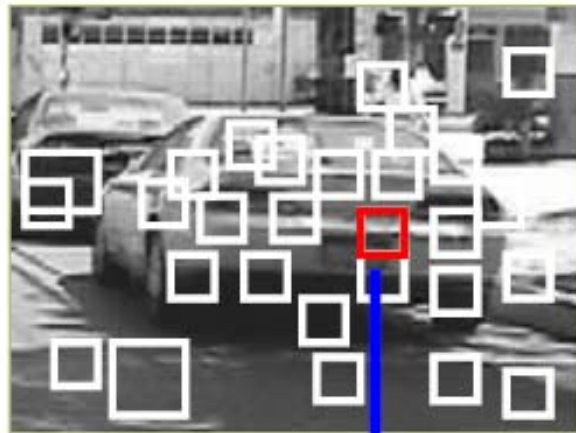

Codewords dictionary

- Nearest neighbors assignment
- K-D tree search strategy

3. Bag of word representation

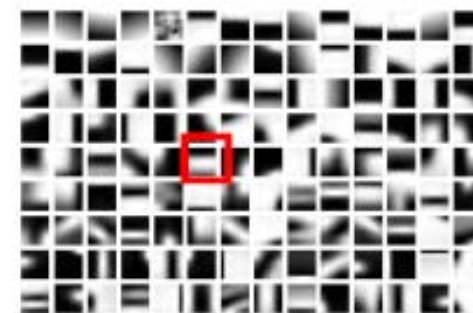
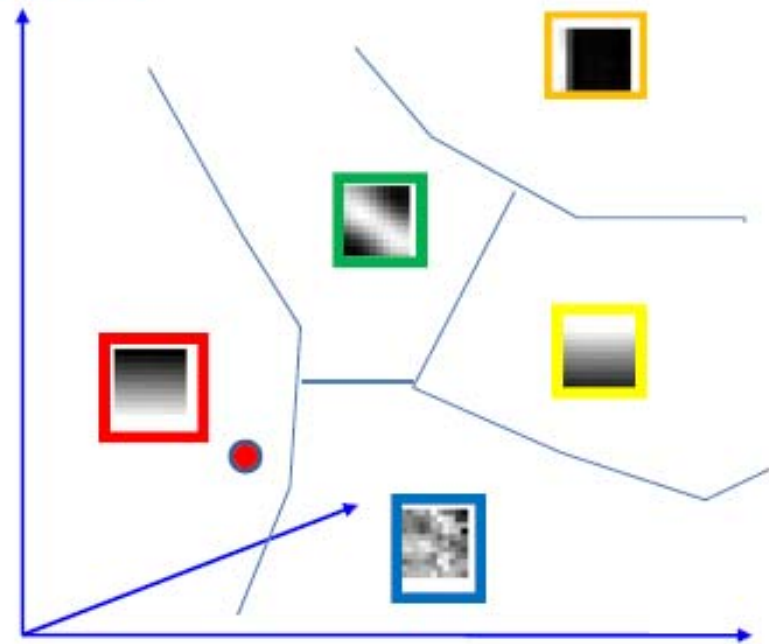
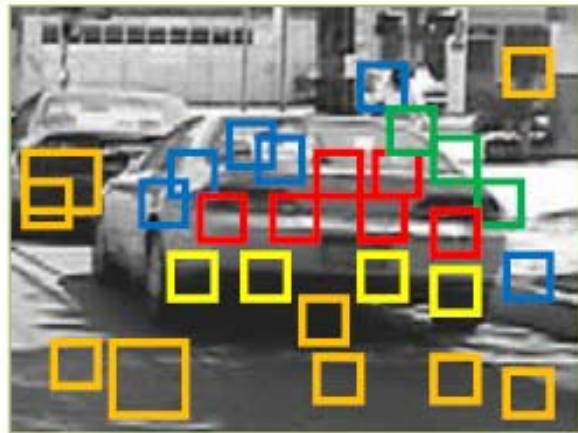

Codewords dictionary

Representation



1. feature detection & representation



2. codewords dictionary



image representation

3.



Learning and Recognition

category models
(and/or) classifiers

Fei-Fei Li

codewords dictionary

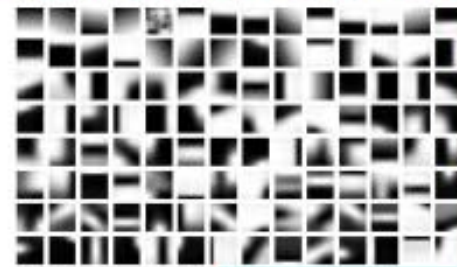

category
decision

73

73 Feb 11

PA2

- Understand and implement a basic image retrieval system
- Use the original UKBenchmark

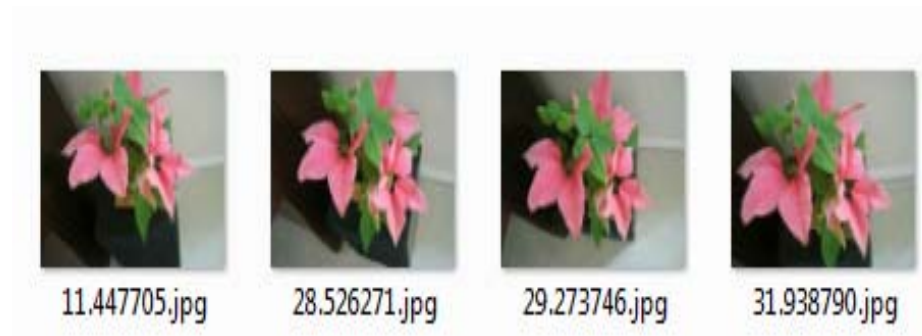
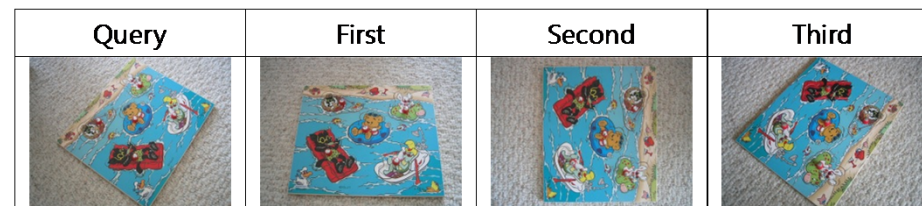

Learning and Recognition

1. Discriminative method:

- NN
- SVM

2. Generative method:

- graphical models

**category models
(and/or) classifiers**

Discriminative classifiers

category models

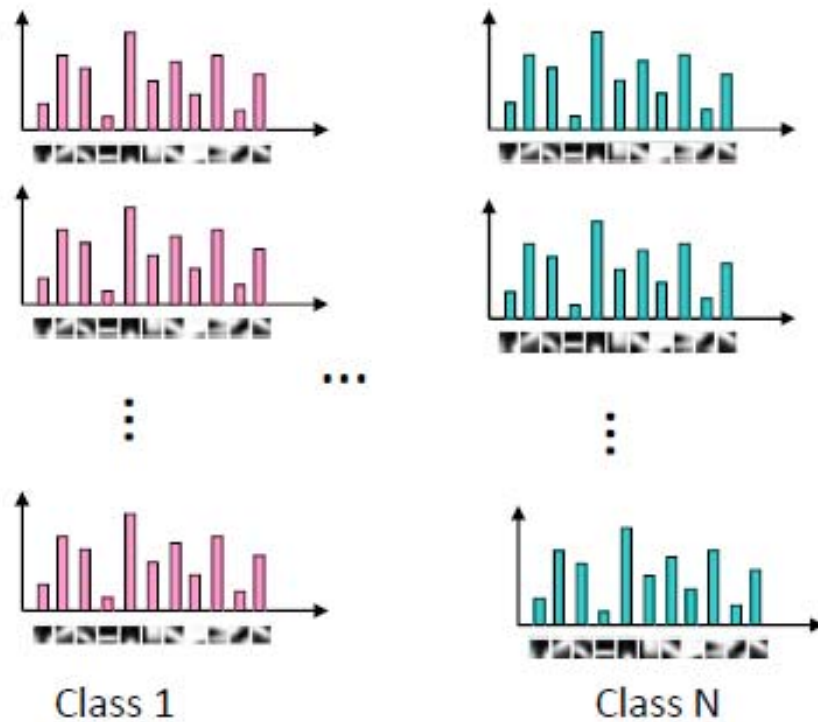

Model space

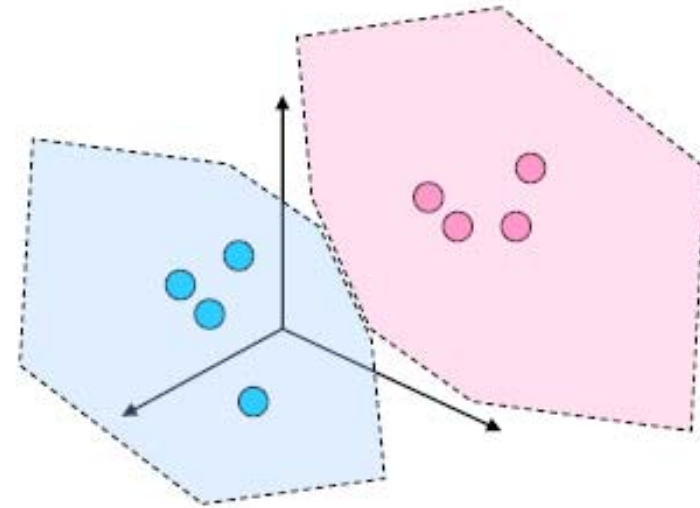

Discriminative classifiers

Query image



Winning class: pink

Model space

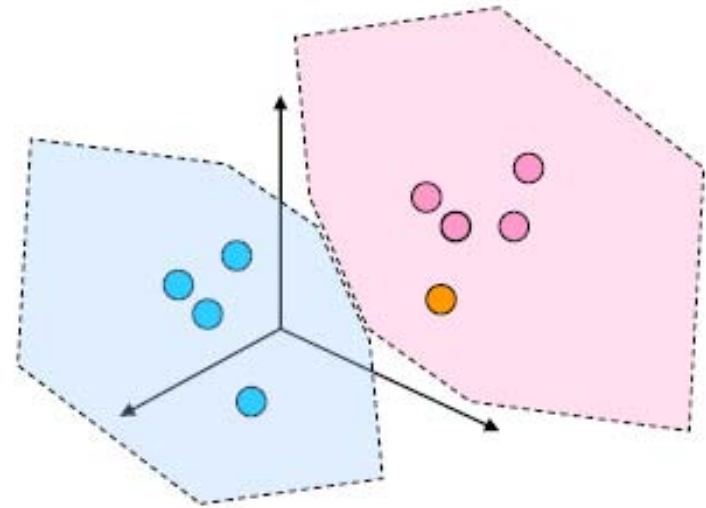

Nearest Neighbors classifier

Query image



Winning class: pink

Model space

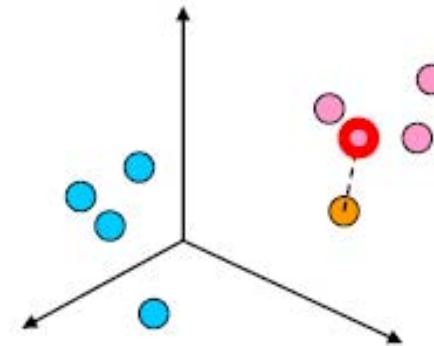

- Assign label of nearest training data point to each test data point

K- Nearest Neighbors classifier

Query image



Winning class: pink

Model space

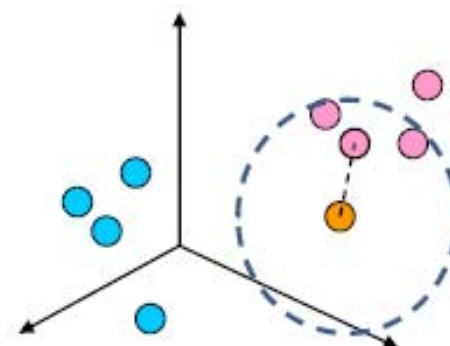

- For a new point, find the k closest points from training data
- Labels of the k points “vote” to classify
- Works well provided there is lots of data and the distance function is good

K- Nearest Neighbors classifier

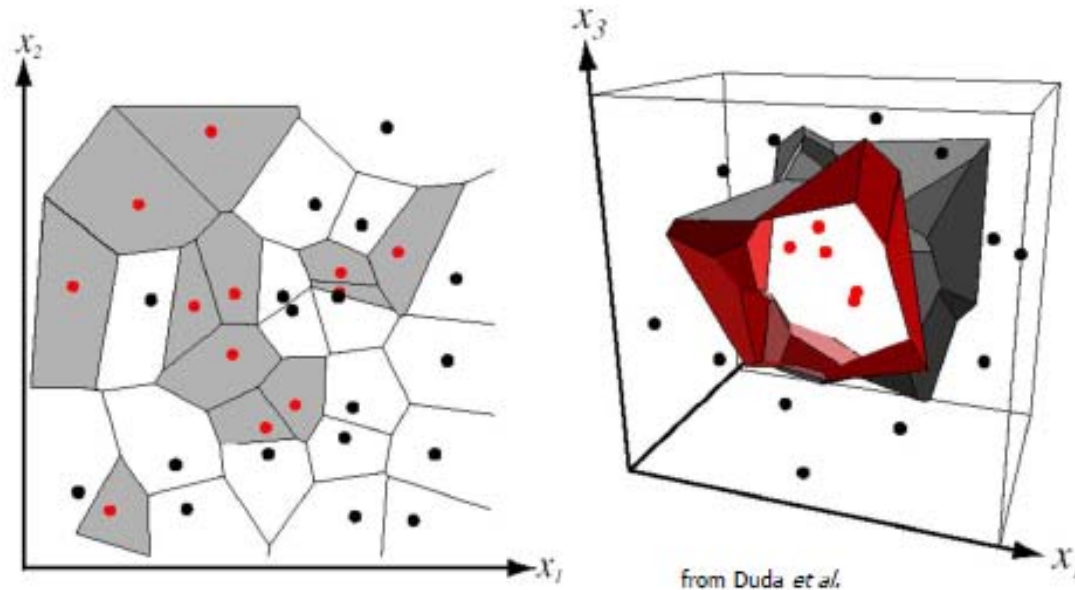

- Voronoi partitioning of feature space for 2-category 2-D and 3-D data
- For k dimensions: k -D tree = space-partitioning data structure for organizing points in a k -dimensional space
- Enable efficient search
- Nice tutorial: <http://www.cs.umd.edu/class/spring2002/cmsc420-0401/pbasic.pdf>

Overview of kd-Trees

- **Binary spatial subdivision**
(special case of BSP tree)
- **Split planes aligned on main axis**
- **Inner nodes: subdivision planes**
- **Leaf nodes: points**

2D Example with Triangles

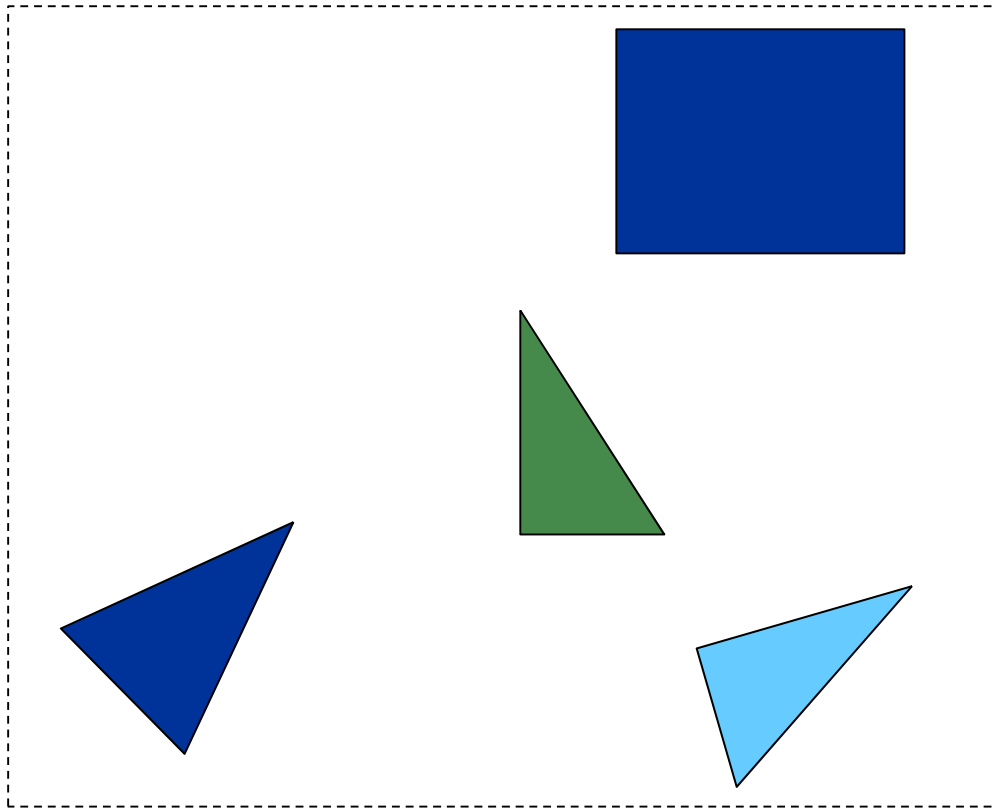

2D Example with Triangles

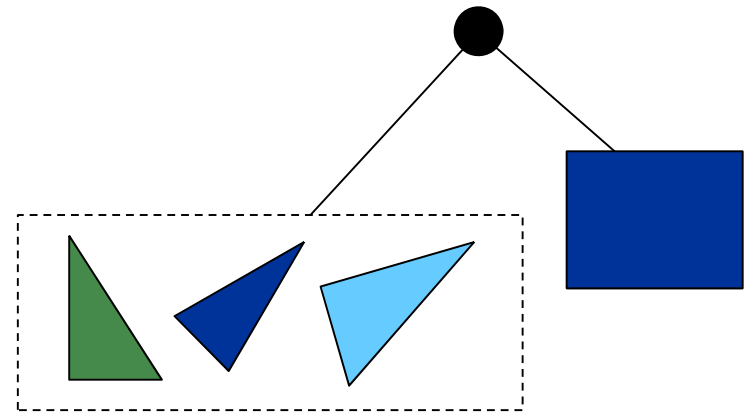
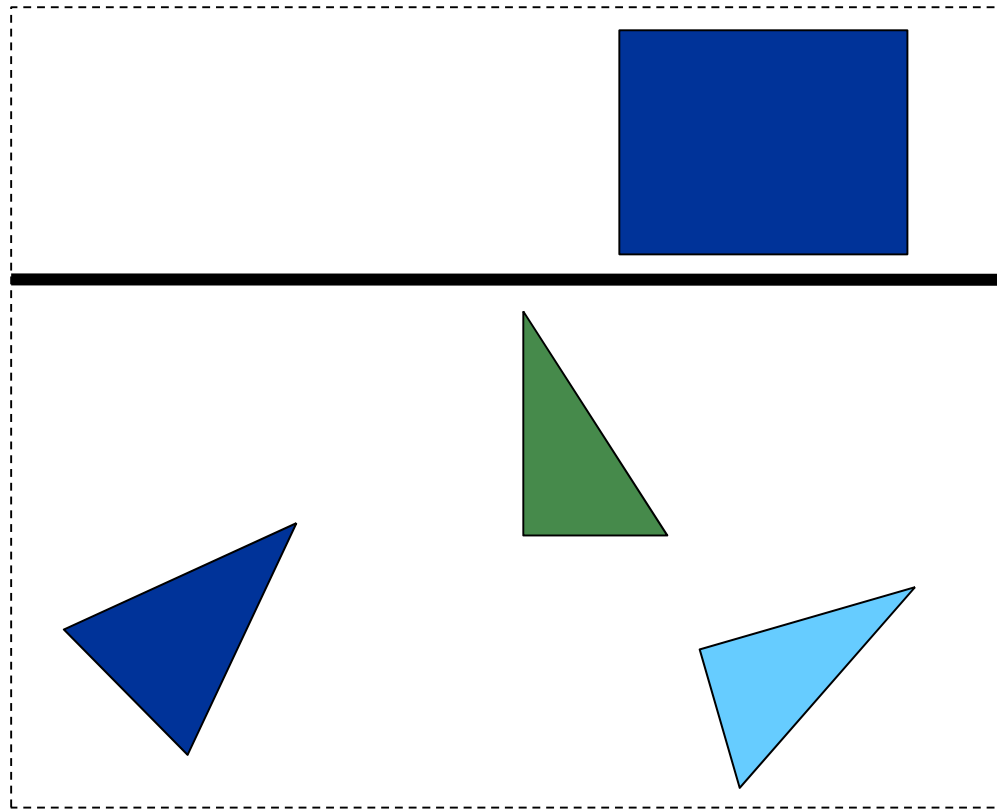

2D Example with Triangles

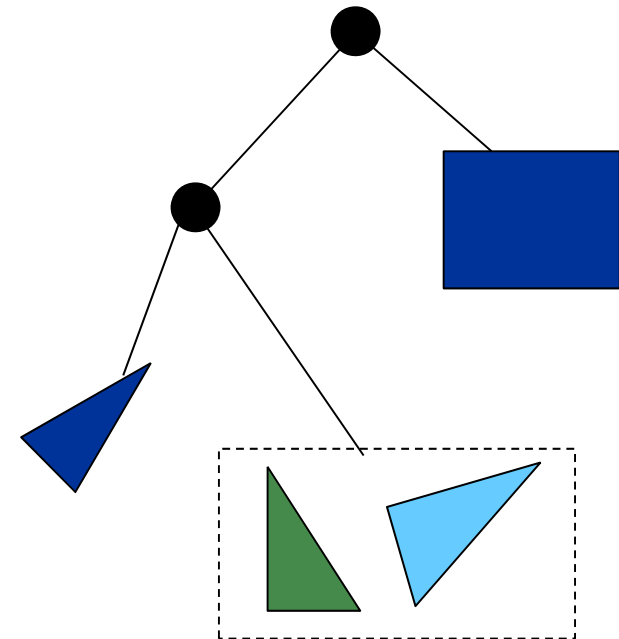
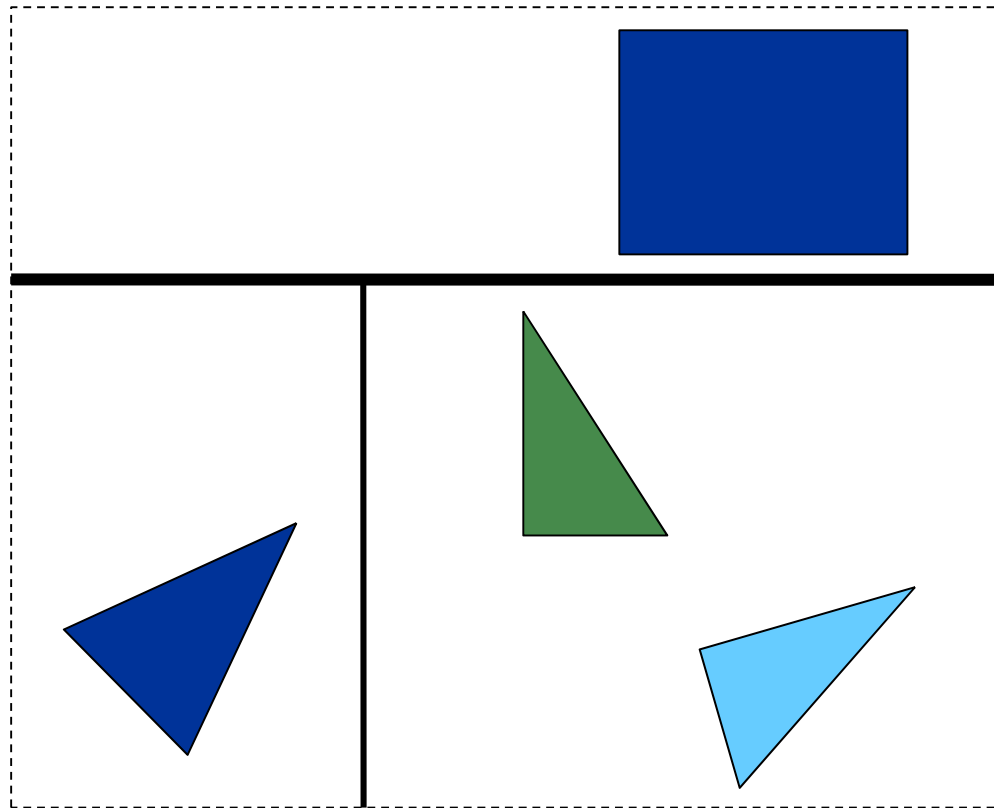

2D Example with Triangles

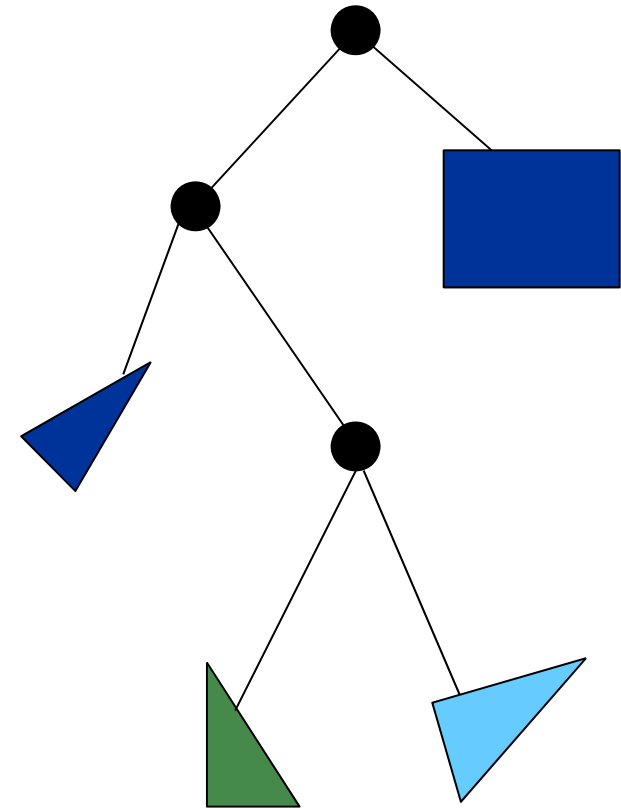
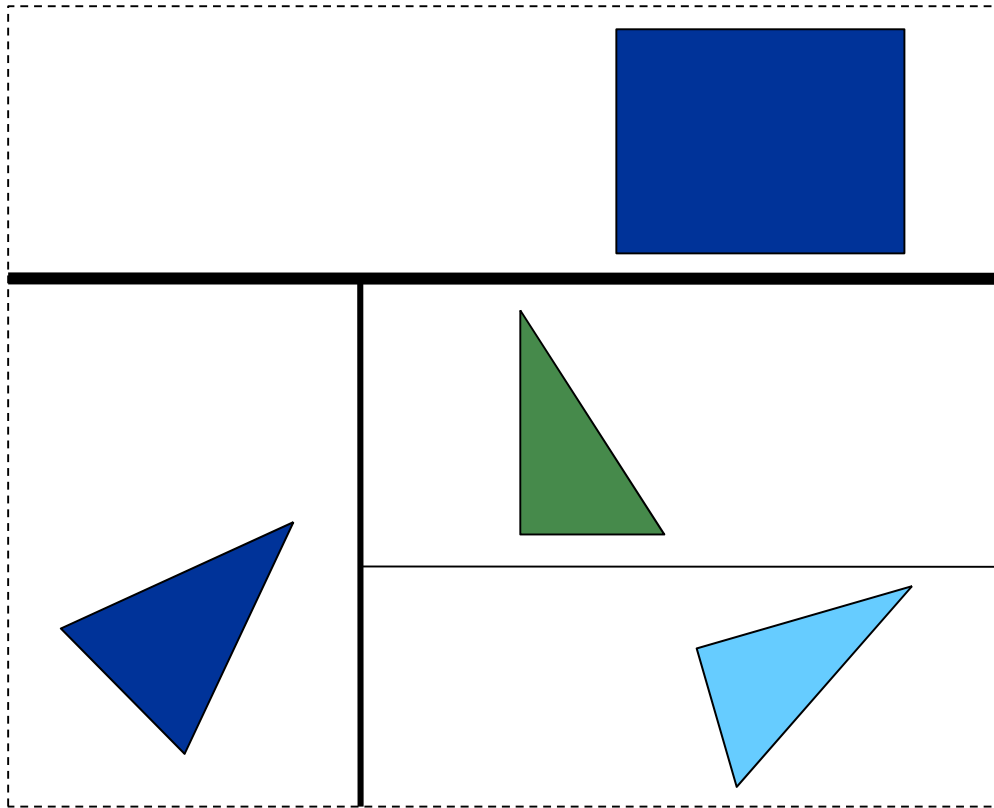

Split Planes

- **How to select axis & split plane?**
- **Option 1:**
 - Choose a random dimension
 - Subdivide in the middle
- **Option 2:**
 - Choose a dimension that has a high variance
- **Any other options**

Nearest Neighbor Search with kd-tree

- **Goal: find k nearest neighbors given a point**
 - Commonly identify approximate, not exact nearest neighbors
- **Apply a depth-first search**
 - Traverse the tree with a stack
- **Or, we can apply a best-bin first search**
 - Traverse more promising nodes first
- **Traverse until we visit a certain number of nodes**

Hashing techniques

- Kd-trees are not scalable
- Hashing arise as better technology

Functions for comparing histograms

- L1 distance

$$D(h_1, h_2) = \sum_{i=1}^N |h_1(i) - h_2(i)|$$

- χ^2 distance (Variance of count data follows mean of the m usually)

$$D(h_1, h_2) = \sum_{i=1}^N \frac{(h_1(i) - h_2(i))^2}{h_1(i) + h_2(i)}$$

- Quadratic distance (*cross-bin*)

$$D(h_1, h_2) = \sum_{i,j} A_{ij} (h_1(i) - h_2(j))^2$$

Jan Puzicha, Yossi Rubner, Carlo Tomasi, Joachim M. Buhmann: [Empirical Evaluation of Dissimilarity Measures for Color and Texture](#). ICCV 1999

Learning and Recognition

1. Discriminative method:

- NN
- SVM

2. Generative method:

- graphical models

Discriminative classifiers (linear classifier)

category models

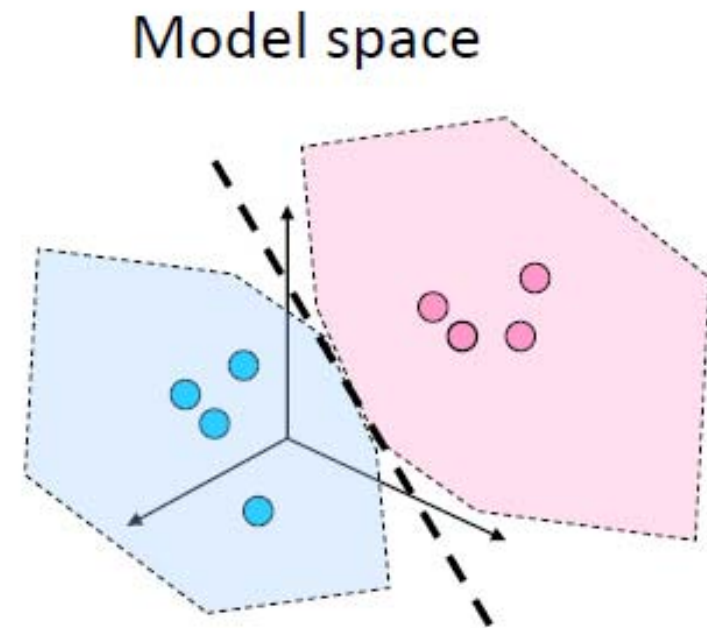
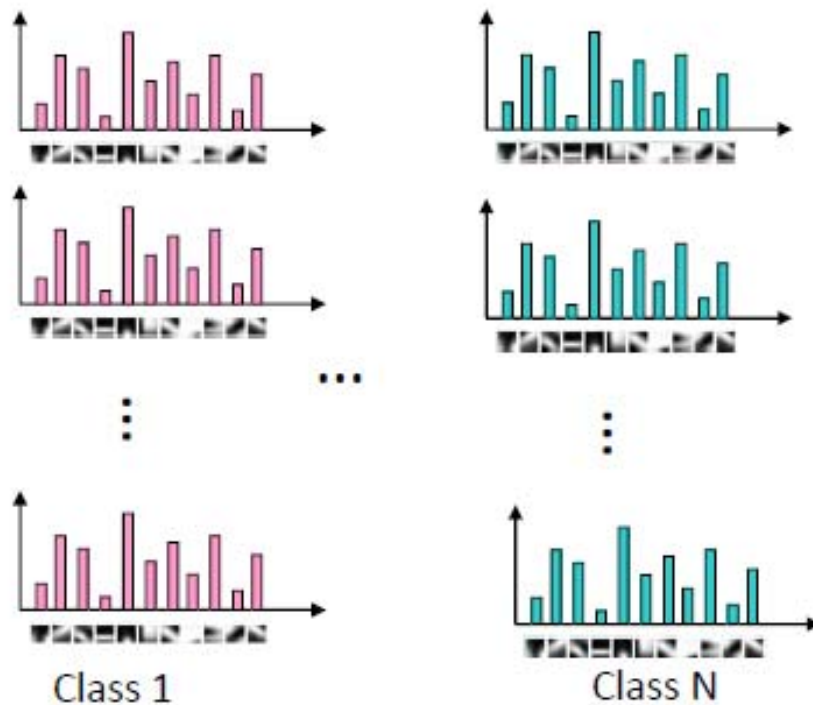

Support vector machines

- Find hyperplane that maximizes the *margin* between the positive and negative examples

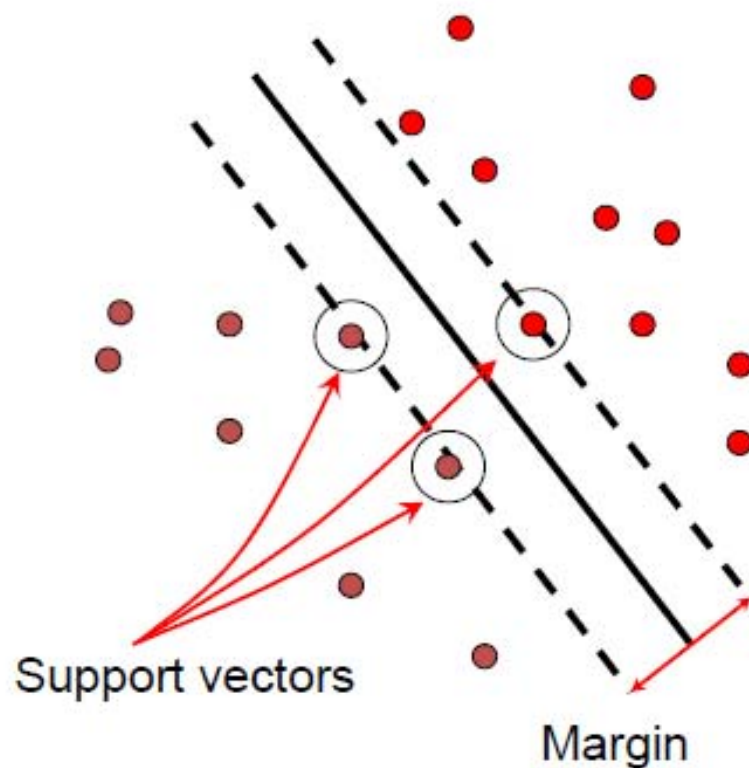

Support vectors: $\mathbf{x}_i \cdot \mathbf{w} + b = \pm 1$

Distance between point and hyperplane: $\frac{|\mathbf{x}_i \cdot \mathbf{w} + b|}{\|\mathbf{w}\|}$

Margin = $2 / \|\mathbf{w}\|$

Solution: $\mathbf{w} = \sum_i \alpha_i y_i \mathbf{x}_i$

Classification function (decision boundary):

$$\mathbf{w} \cdot \mathbf{x} + b = \sum_i \alpha_i y_i \mathbf{x}_i \cdot \mathbf{x} + b$$

Credit slide: S. Lazebnik

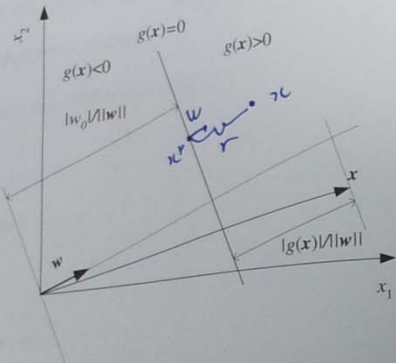

Figure 10.2 The geometric interpretation of the linear discriminant.

where x_p is the normal projection of x onto the hyperplane and r gives us the distance from x to the hyperplane, negative if x is on the negative side, and positive if x is on the positive side (see figure 10.2). Calculating $g(x)$ and noting that $g(x_p) = 0$, we have

$$(10.4) \quad r = \frac{g(x)}{\|w\|}$$

We see then that the distance to origin is

$$(10.5) \quad r_0 = \frac{w_0}{\|w\|}$$

Thus w_0 determines the location of the hyperplane with respect to the origin, and w determines its orientation.

10.3.2 Multiple Classes

When there are $K > 2$ classes, there are K discriminant functions. When they are linear, we have

$$(10.6) \quad g_i(x|w_i, w_{i0}) = w_i^T x + w_{i0}$$

$$g(x) = w_1 \cdot x_1 + w_2 \cdot x_2 + w_0$$

$$= w^T \cdot x + w_0$$

$$g(x_p) = 0 = w^T \cdot x_p + \frac{w_0}{\|w\|} \cdot r$$

$$\frac{g(x)}{\|w\|} = \frac{w^T}{\|w\|} \cdot x + \frac{w_0}{\|w\|}$$

$$\frac{g(x_p)}{\|w\|} = 0 = \frac{w^T}{\|w\|} \cdot x_p + \frac{w_0}{\|w\|}$$

$$\Rightarrow \frac{w_0}{\|w\|} = - \frac{w^T}{\|w\|} \cdot x_p$$

$$\frac{g(x)}{\|w\|} = \frac{w^T}{\|w\|} \cdot x - \frac{w^T}{\|w\|} \cdot x_p$$

$$= \left(\frac{w^T}{\|w\|} \right) (x - x_p)$$

$$= 1 \cdot r \quad (\text{or } (0))$$

$$= r$$

Support vector machines

- Classification

$$\mathbf{w} \cdot \mathbf{x} + b = \sum_i \alpha_i y_i \mathbf{x}_i \cdot \mathbf{x} + b$$

Test point

if $\mathbf{x} \cdot \mathbf{w} + b \geq 0 \rightarrow$ *class 1*

if $\mathbf{x} \cdot \mathbf{w} + b < 0 \rightarrow$ *class 2*

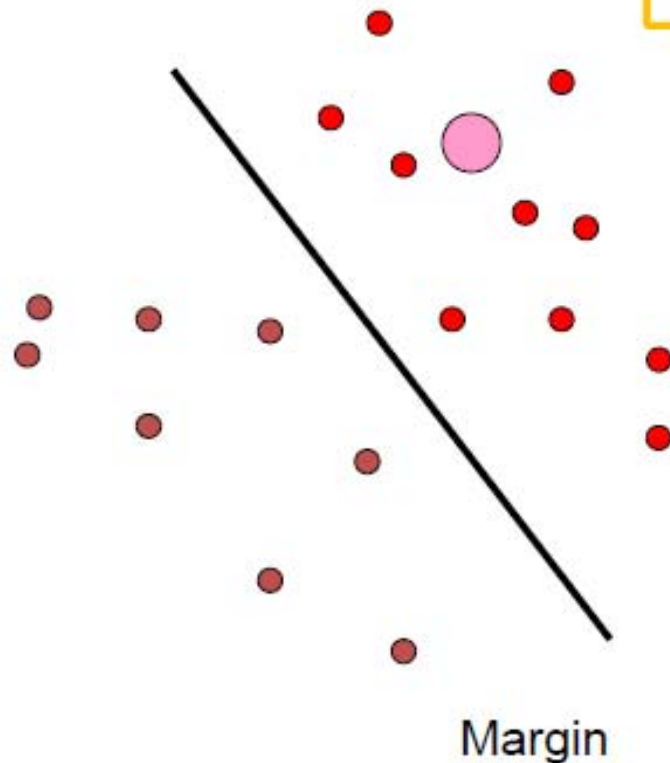

C. Burges, [A Tutorial on Support Vector Machines for Pattern Recognition](#), Data Mining and Knowledge Discovery, 1998

Nonlinear SVMs

- Datasets that are linearly separable work out great:

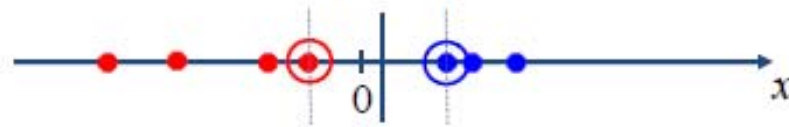

- But what if the dataset is just too hard?



- We can map it to a higher-dimensional space:

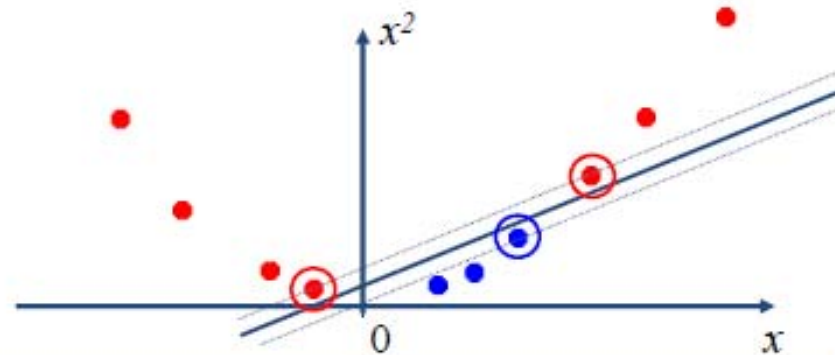

Slide credit: Andrew Moore

Nonlinear SVMs

- General idea: the original input space can always be mapped to some higher-dimensional feature space where the training set is separable:

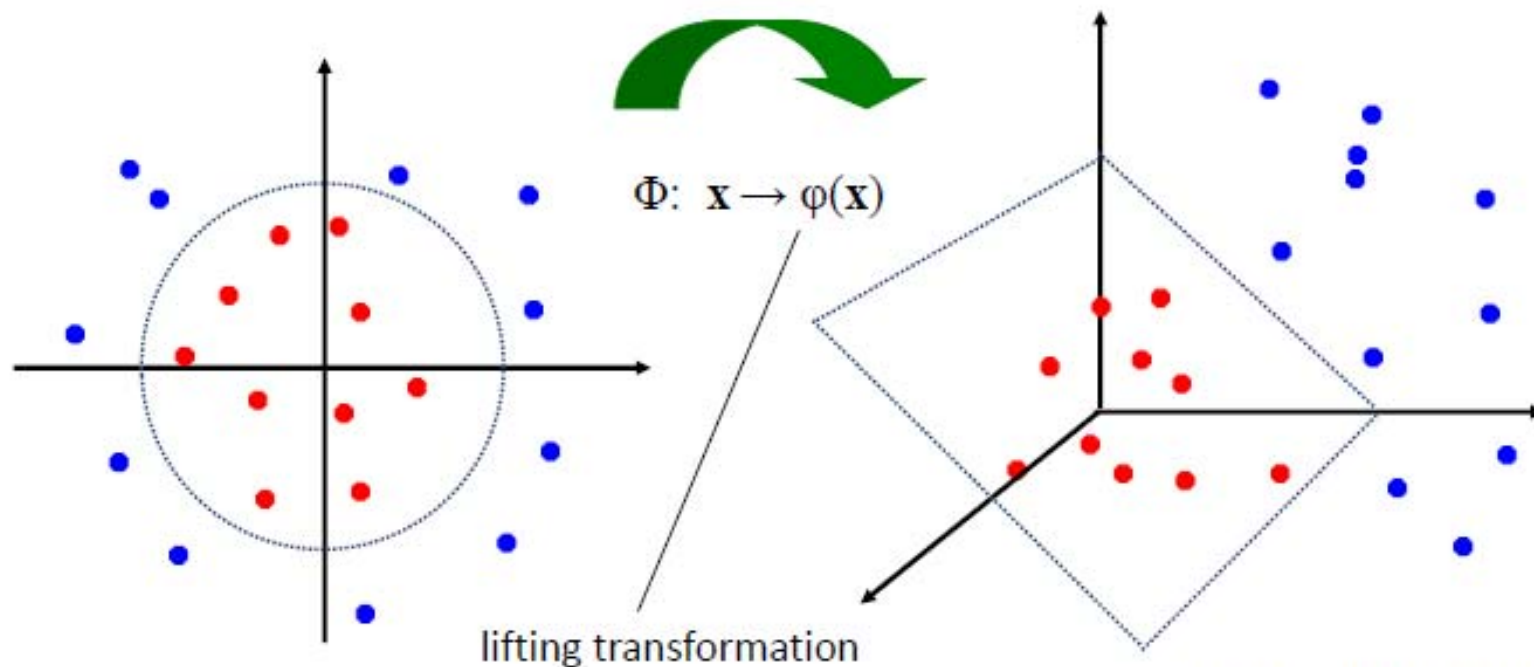

Slide credit: Andrew Moore

What about multi-class SVMs?

- No “definitive” multi-class SVM formulation
- In practice, we have to obtain a multi-class SVM by combining multiple two-class SVMs
- One vs. others
 - Training: learn an SVM for each class vs. the others
 - Testing: apply each SVM to test example and assign to it the class of the SVM that returns the highest decision value
- One vs. one
 - Training: learn an SVM for each pair of classes
 - Testing: each learned SVM “votes” for a class to assign to the test example

Credit slide: S. Lazebnik

SVMs: Pros and cons

- Pros
 - Many publicly available SVM packages:
<http://www.kernel-machines.org/software>
 - Kernel-based framework is very powerful, flexible
 - SVMs work very well in practice, even with very small training sample sizes
- Cons
 - No “direct” multi-class SVM, must combine two-class SVMs
 - Computation, memory
 - During training time, must compute matrix of kernel values for every pair of examples
 - Learning can take a very long time for large-scale problems

Object recognition results

- ETH-80 database of 8 object classes

(Eichhorn and Chapelle 2004)

- Features:

- Harris detector
- PCA-SIFT descriptor, $d=10$



- Achieves a high accuracy (about 80%)

Slide credit: Kristen Grauman

Discriminative models

Nearest neighbor



Shakhnarovich, Viola, Darrell 2003
Berg, Berg, Malik 2005...

Neural networks

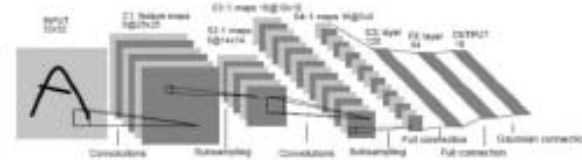

LeCun, Bottou, Bengio, Haffner 1998
Rowley, Baluja, Kanade 1998

...

Support Vector Machines

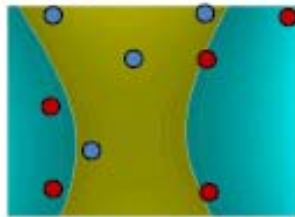

Guyon, Vapnik, Heisele,
Serre, Poggio...

Latent SVM

Structural SVM

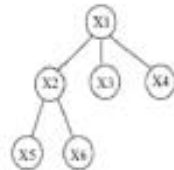

Felzenszwalb 00
Ramanan 03...

Boosting



Viola, Jones 2001,
Torralba et al. 2004,
Opelt et al. 2006,...

Source: Vittorio Ferrari, Kristen Grauman, Antonio Torralba

Learning and Recognition

1. Discriminative method:

- NN
- SVM

2. Generative method:

- graphical models

→ Model the probability distribution that produces a given bag of features

Generative models

1. Naïve Bayes classifier

- Csurka Bray, Dance & Fan, 2004

2. Hierarchical Bayesian text models (pLSA and LDA)

- Background: Hoffman 2001, Blei, Ng & Jordan, 2004
- Object categorization: Sivic et al. 2005, Sudderth et al. 2005
- Natural scene categorization: Fei-Fei et al. 2005

Some notations

- **w**: a collection of all N codewords in the image

$$\mathbf{w} = [w_1, w_2, \dots, w_N]$$

- **c**: category of the image

the Naïve Bayes model

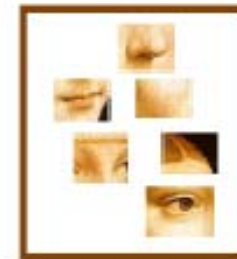
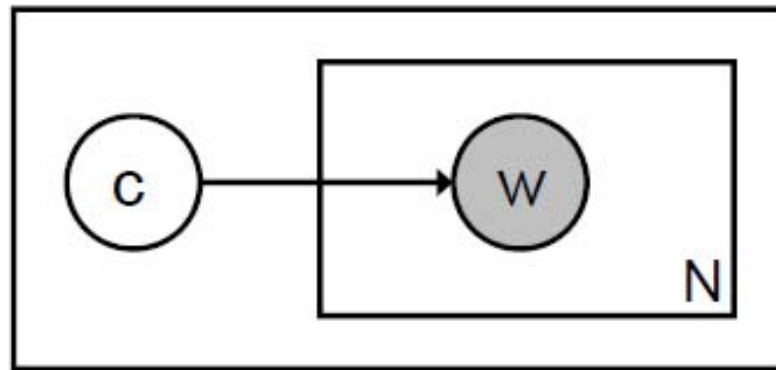

Graphical model

Posterior = $p(c | w) \propto p(c) p(w | c)$

probability
that image I is
of category c

Prior prob. of
the object classes

Image likelihood
given the class



the Naïve Bayes model

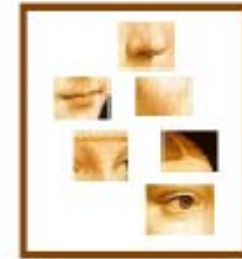
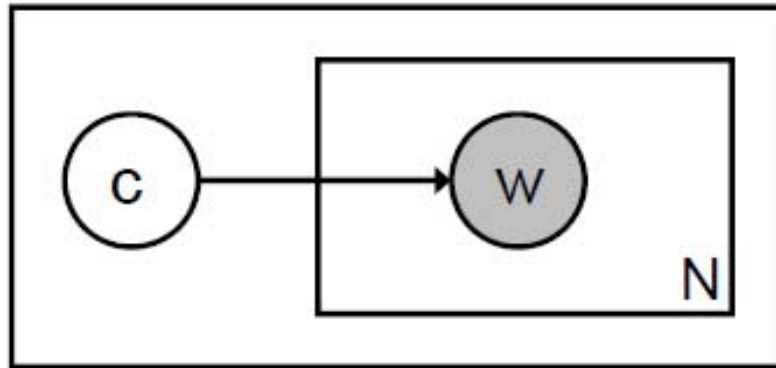

Graphical model

$$c^* = \arg \max_c p(c | w) \propto p(c) p(w | c) = p(c) \prod_{n=1}^N p(w_n | c)$$

Object class decision

Likelihood of i th visual word given the class

Estimated by empirical frequencies of code words in images from a given class



Our in-house database contains 1776 images in seven classes¹: faces, buildings, trees, cars, phones, bikes and books. Fig. 2 shows some examples from this dataset.



Csurka et al. 2004

Table 1. Confusion matrix and the mean rank for the best vocabulary ($k=1000$).

True classes →	<i>faces</i>	<i>buildings</i>	<i>trees</i>	<i>cars</i>	<i>phones</i>	<i>bikes</i>	<i>books</i>
<i>faces</i>	76	4	2	3	4	4	13
<i>buildings</i>	2	44	5	0	5	1	3
<i>trees</i>	3	2	80	0	0	5	0
<i>cars</i>	4	1	0	75	3	1	4
<i>phones</i>	9	15	1	16	70	14	11
<i>bikes</i>	2	15	12	0	8	73	0
<i>books</i>	4	19	0	6	7	2	69

Csurka et al. 2004

Generative vs discriminative

- Discriminative methods
 - Computationally efficient & fast
- Generative models
 - Flexibility in modeling parameters

Weakness of BoW the models

- No rigorous geometric information of the object components
- It's intuitive to most of us that objects are made of parts – no such information
- Not extensively tested yet for
 - View point invariance
 - Scale invariance
- Segmentation and localization unclear

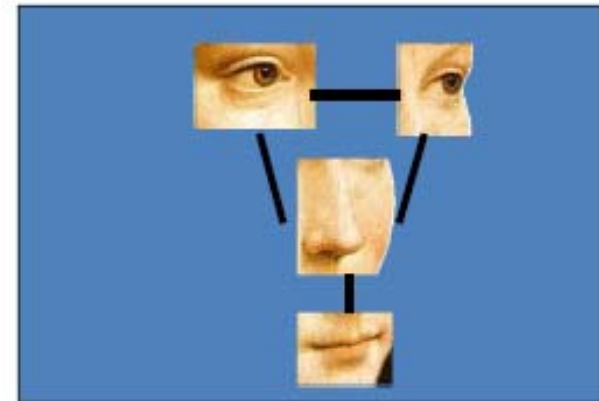
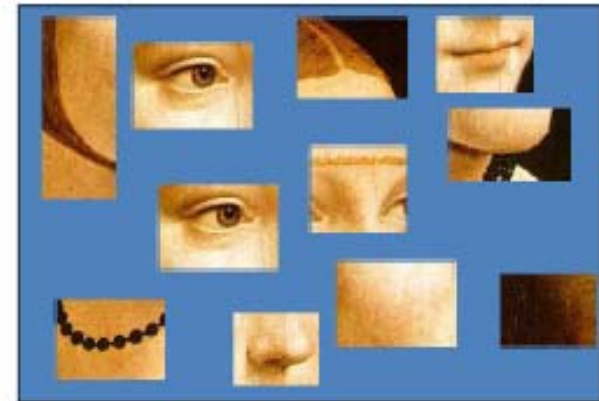

What have we learned today?

- Bag of Words models
 - Basic representation
 - Different learning and recognition algorithms

Next Time...

- **Various image retrieval systems**

Homework for Every Class

- Go over the next lecture slides
- Come up with one question on what we have discussed today
 - 1 for typical questions (that were answered in the class)
 - 2 for questions with thoughts or that surprised me
- Write questions at least 4 times